

Orion[®]
FLEX[™]
S E R I E S

LP & HP Series Turntable Stretch Wrapping Systems

Flex turntable stretch wrappers are available in two configurations so you can be sure to find the right machine for your application.

Automatic

Flex A Series machines offer maximum efficiency and economy. Available in high or low profile models.

Deluxe

The Flex D Series is the semi-automatic workhorse of the industry. Available in high or low profile models.





Flex A models eliminate the need for operators to attach and cut the stretch film. Simply place the pallet load on the machine, and pull a lanyard switch while backing away. The machine will perform the entire wrap cycle automatically without the need for an operator to tie the film tail to the load at the beginning of the cycle, and detach it at the end. This will greatly impact the efficiency of your stretch packaging operation by keeping your operators busy with other tasks while the machine is wrapping.



Flex Low Profile Automatic Performance Features

- Automatic Cycle Reduces Labor
- 15 RPM Variable Speed with 'soft-start'
- 5,000 lb. Maximum Load Weight Capacity
- Economical 260% Powered Film Pre-stretch
- 63" Diameter Turntable for Loads up to 50"x50"
- Max Load Height 80" Standard, 110" Optional
- Load via Pallet Jack*, Electric Walkie* or Forklift
- AC/VFD Motors Reduce Maintenance
- Full Surround Deck Protects Turntable
- Structural Steel Frame for Durability
- Easy to Load Film From Side
- Forklift Portable from Front or Rear



Flex High Profile Automatic Performance Features

- Automatic Cycle Reduces Labor
- 15 RPM Variable Speed with 'soft-start'
- 5,000 lb. Maximum Load Weight Capacity
- Economical 260% Powered Film Pre-stretch
- 48"x48" Turntable for Loads up to 50"x50"
- Max Load Height 80" Standard, 110" Optional
- Octagonal Turntable for Easy Forklift Loading
- AC/VFD Motors Reduce Maintenance
- Structural Steel Frame for Durability
- Easy to Load Film From Side
- Forklift Portable from Front or Rear



Turntable support on the Flex HPA provided by a precision ring bearing for maximum durability.

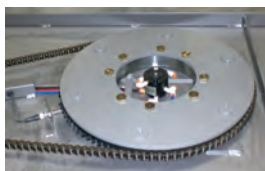

A precision ring bearing and Orion's DuraGlide cams provide reliable support for loads weighing up to 5,000 pounds.

* Optional ramp required for pallet jack, electric walkie loading



Control Panel HMI on D & A models

A versatile touch screen display guides users through a range of menu items for easy adjustment of operating parameters. Settings can be password protected for added security.



Flex models use an industrial grade woven belt carriage lift for long service life and reliability. Orion's "drop lock" system prevents carriage movement in the unlikely event of belt breakage.

Flex stretch wrapping machines help you reduce material costs, labor costs and because they're so well built, your true cost of ownership.

Flex machines are built rock solid

All Flex models are built from heavy gauge structural and formed steel to assure a long lasting, durable machine. For convenience, all machines are forklift portable from either the front or rear of the machine. Mounting tabs are provided for easy lagging to the floor if desired.



PLC Controller

- Non-Proprietary PLC
- NEMA 12 Rated Control Box
- A models Include Lanyard switch for remote start
- Large E-Stop / Cycle Pause Button
- Power Lockout Disconnect Switch

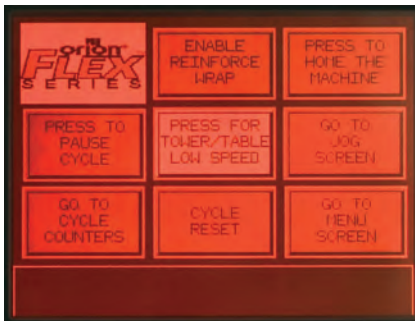

Orion Insta-Thread™ Film Delivery System

Film threading is fast, easy and safe thanks to simple "drop-in" film loading. Simply open the gate, drop the film tail in, and close the gate.



Graphic instructions on top of the carriage guide the operator through film threading.

Orion Insta-Thread™ film carriage and film tail treatment mechanism on Flex LPA (top) and Flex HPA (bottom).



Flex D models are the result of 25 years of experience building rugged, reliable semi-automatic stretch wrapping machines. Built for most demanding industrial environments, the Flex Deluxe Series features a durable steel framework, AC motors, a belt-driven carriage lift and a heavy-duty turntable support system. D and A Series machines include the 260% (standard) Insta-Thread film delivery system to assure you get the maximum power and economy out of every foot of stretch film you use.

Flex Low Profile Deluxe Performance Features

- 15 RPM Variable Speed with 'soft-start'
- 5,000 lb. Maximum Load Weight Capacity
- Economical 260% Powered Film Pre-stretch
- 63" Diameter Turntable for Loads up to 55"x55"
- Max Load Height 80" Standard, 110" Optional
- Load via Pallet Jack*, Electric Walkie* or Forklift
- AC/VFD Motors Reduce Maintenance
- Full Surround Deck Protects Turntable
- Structural Steel Frame for Durability
- Easy to Load Film From Side
- Forklift Portable from Front or Rear
- DuraGlide Support Bearings for quiet & reliable operation



* Optional loading ramp required. Above model shown with optional ramp

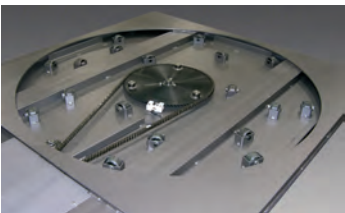

Flex A and D low profile models feature a heavy duty steel base with structural fork tubes that run the length of the machine. Turntable support provided by specially designed casters.



Flex High Profile Deluxe Performance Features

- 15 RPM Variable Speed with 'soft-start'
- 5,000 lb. Maximum Load Weight Capacity
- Economical 260% Powered Film Pre-stretch
- 48"x48" Turntable for Loads up to 55"x55"
- Max Load Height 80" Standard, 110" Optional
- Octagonal Turntable for Easy Forklift Loading
- AC/VFD Motors Reduce Maintenance
- Structural Steel Frame for Durability
- Ergonomically Friendly Design
- Forklift Portable from Front or Rear
- 8 Heavy-Duty Turntable Support Casters

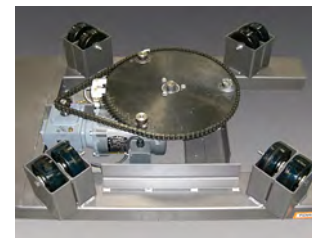

Flex HPD high profile offers reliable chain drive, a heavy duty steel frame and 8 industrial casters for turntable support.



Feature for feature, dollar for dollar, Orion Flex stretch wrappers offer you more value than any competitive machine on the market today.

State-of-the-art Controller Technology

From its clean and simple user interface on the outside to its sophisticated programmable logic controller and AC variable frequency drives inside, every aspect of the Flex control package has been designed for maximum reliability, flexibility and ease-of-use.



Optional Heavy Duty Ramp for Easy Loading via Electric Walkie or Pallet Jack

An optional Flex loading ramp can be placed in any one of three loading positions: right, left or center. Flex LPA and LPD models feature a full surround deck around the turntable for added convenience when placing loads. Gradual turntable acceleration (soft-start) assures that light or unstable loads can be safely wrapped.



Orion Insta-Thread™ Film Delivery System

Flex A and D Series machines help you reduce cost with every load you wrap. With a standard film pre-stretch rate of 260% (higher than most competitive machines) you'll not only save money by using less film, the film on the load will be stronger, so loads are securely wrapped for storage or shipping.

Features & Available Options

Flex FEATURES Chart	LPA	HPA	LPD	HPD
Automation				
Automatic Load Height Detection	Std.	Std.	Std.	Std.
Automatic Film Clamp/Cut	Std.	Std.	N A	N A
Automatic Film Press-to-Load	Std.	Std.	N A	N A
Automatic Film Severance - InstaCut	N A	N A	Option	Option
Controls & Drives	LPA	HPA	LPD	HPD
Industrial PLC (non proprietary)	Std.	Std.	Std.	Std.
Touch Screen HMI Display	Std.	Std.	Std.	Std.
Separate UP/DOWN Carriage Speeds	Std.	Std.	Std.	Std.
NEMA 12 Control Box	Std.	Std.	Std.	Std.
AC Motors with Variable Frequency Drives	Std.	Std.	Std.	Std.
Password Lock-Out Capability	Std.	Std.	Std.	Std.
Spanish & French HMI Capability	Std.	Std.	Std.	Std.
Turntable	LPA	HPA	LPD	HPD
4,000 Pound Capacity	N A	N A	N A	N A
5,000 Pound Capacity	Std.	Std.	Std.	Std.
6,000 Pound Capacity	Option	Option	Option	Option
Steel Deck Frame Surrounding Turntable	Std.	N A	Std.	N A
8 Point Caster Support	N A	N A	N A	Std.
Multiple DuraGlide Support Bearings	Std.	N A	Std.	N A
Precision Ring Bearing Support	Std.	Std.	Option	Option
Direct Chain & Sprocket Drive	Std.	Std.	Std.	Std.
Film Carriage	LPA	HPA	LPD	HPD
InstaThread Premium @ 260%	Std.	Std.	Std.	Std.
InstaThread @ 200%	N A	N A	N A	N A
Automatic Force-to-Load Control	Std.	Std.	Std.	Std.
Drop-In Film Threading	Std.	Std.	Std.	Std.
Lifetime Warranty Stretch Rollers	Std.	Std.	Std.	Std.
Adjustable Ultra Low Wrap Feature	Std.	N A	Std.	N A
Structural	LPA	HPA	LPD	HPD
Full Length Structural Steel Base	Std.	Std.	Std.	Std.
Forklift Portable from Front & Rear	Std.	Std.	Std.	Std.
Steel Deck Frame Surrounding Turntable	Std.	N A	Std.	N A
Electric-Walkie or Pallet-Jack Ramp	Option	N A	Option	N A
Safe Interaction	LPA	HPA	LPD	HPD
Drop-In Film Threading	Std.	Std.	Std.	Std.
Film Carriage "Drop-Lock" Technology	Std.	Std.	Std.	Std.
Film Carriage Down Obstacle Detection	Std.	Std.	Std.	Std.
Steel Guarding at Film Clamp/Cut/Press	Std.	Std.	N A	N A

Popular Flex Series Options

Contact your local Orion distributor for the best configuration for your application.

- Loading Ramp
- Oversize Load Configuration
- 30" Insta-Thread™ Film Carriage
- Insta-Cut™ Automatic Film Web Severance
- "Stretch & Weigh™" Scale Package
- Dual Turntable Option
- Extra Heavy Load Weight Capacity
- Environmental Options
- French or Spanish HMI Language



The Insta-Cut option boosts production by eliminating the need for operators to manually sever the film web at the end of the cycle.



The split base option is used with oversized loads. This option can be combined with the scale option to provide an accurate load weight.



The dual turntable option increases efficiency by allowing simultaneous load staging and wrapping.

Flex LP Models

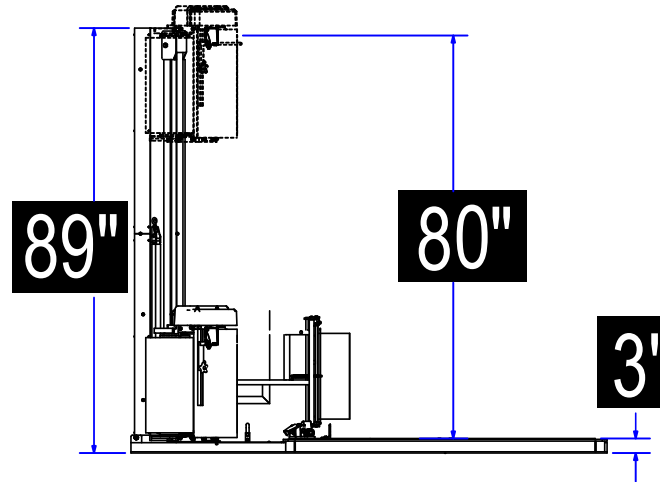
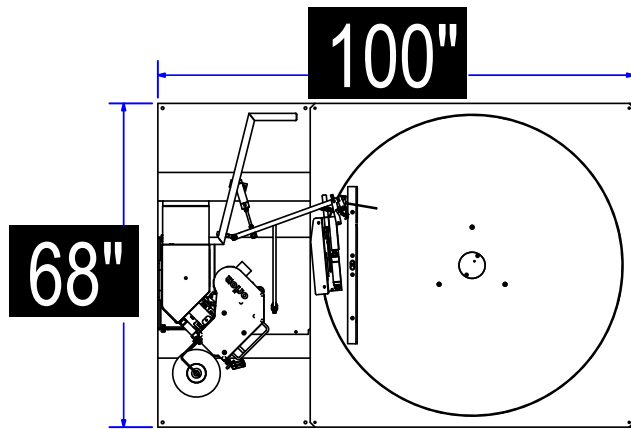

Flex HP Models

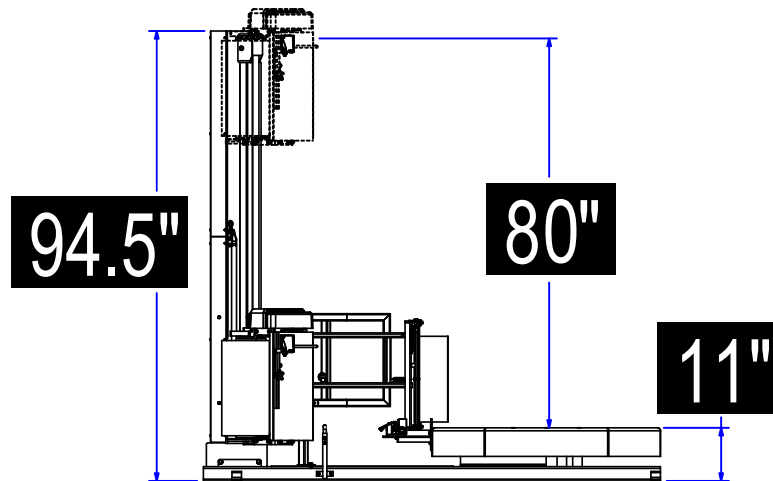
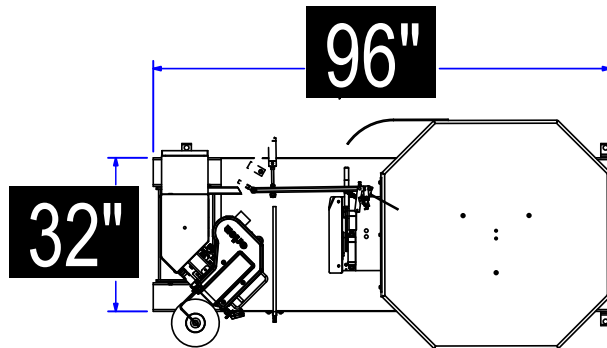



Orion Packaging Systems, LLC
A Division of Pro Mach, Inc.
4750 County Rd. 13 NE
Alexandria, MN 56308
Toll Free (800) 333-6556
Telephone: (320) 852-7705
Fax: (320) 852-7621
Email: sales@orionpackaging.com
Web: www.orionpackaging.com
Bulletin #FLEX_09/11CC



Proudly Made in the U.S.A.

All dimensions approximate. Orion Packaging Systems reserves the right to change specifications without notice.